

Supplementary Materials

Quantum Wavemetry via the M th-Power Unitary of a Mach-Zehnder Interferometer

Byoung S. Ham

The CBW-based Fizeau-type quantum wavemeter architecture is shown for a scalable Mth power of the MZI unitary to give a hint for the extension of the lower inset of Fig. 1. Figure S1 is for $M=3$, where the unused output port is applied for one more unit Fizeau MZI shown in the inset of Fig. 1, resulting in tripled interference fringes compared to those of the typical MZI. For the CBW quantum wavemeter, the dummy MZI's phase is set for $\psi = 0$.

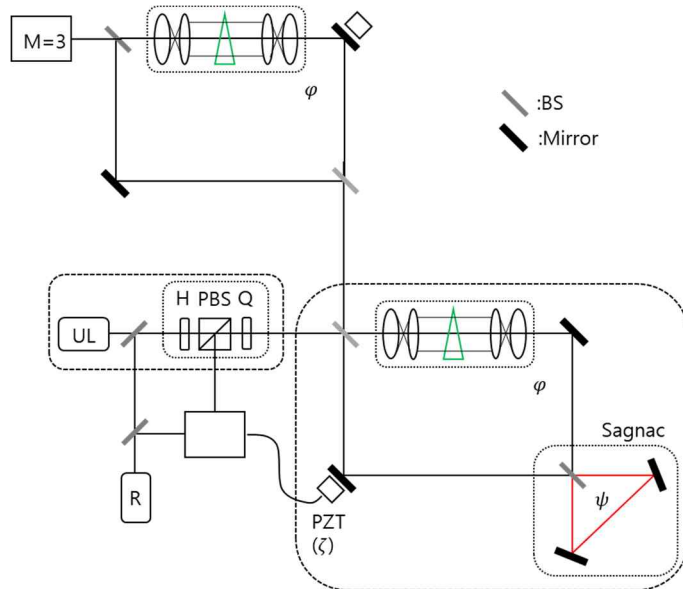

Fig. S1. $M=3$ CBW quantum wavemeter. Both MZIs are identical, including the phase φ control.

Figure S2 is for the $M=4$ CBW quantum wavemeter, which is extended from the inset of Fig. 1. For this, an exact copy of the round-trip Fizeau-MZI is added, resulting in quadrupled fringes compared to the reference MZI.

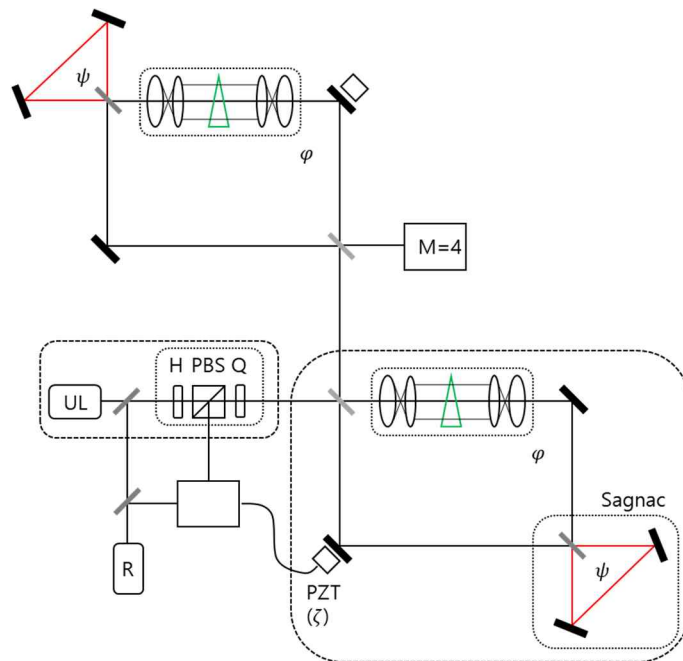

Fig. S2. $M=4$ CBW quantum wavemeter. Both Fizeau-MZIs are identical, including φ control.

Figure S3 is for the $M=5$ CBW quantum wavemeter, which is extended from the inset of Fig. 1. For this, single-pass Fizeau-MZI is added to Fig. S2, where all phase controls are synchronized.

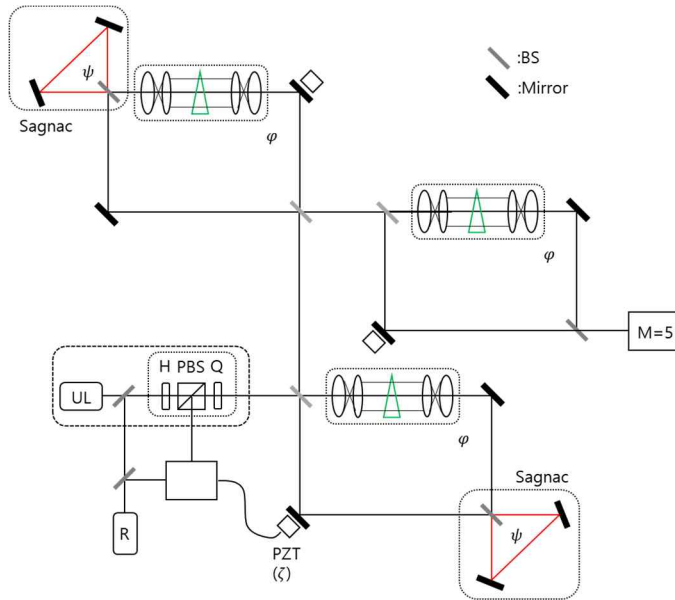

Fig. S3. $M=5$ CBW quantum wavemeter. All MZIs are synchronized for the φ -phase control.

Figure S4 is for the $M=6$ CBW quantum wavemeter, which is extended from the inset of Fig. 1. For this, all three Fizeau-MZIs are identical, including the phase control of φs .

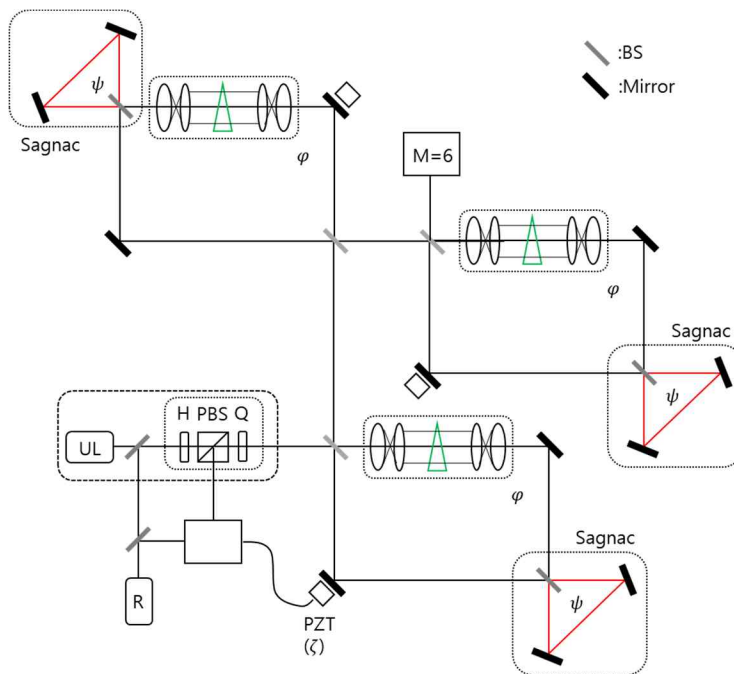

Fig. S4. $M=6$ CBW quantum wavemeter. All Fizeau-MZIs are identical with synchronized phase controls.

Figure S5 is for the $M=7$ CBW quantum wavemeter, which is extended from the inset of Fig. 1. For this, all MZIs are identical, whose corresponding phases are synchronized.

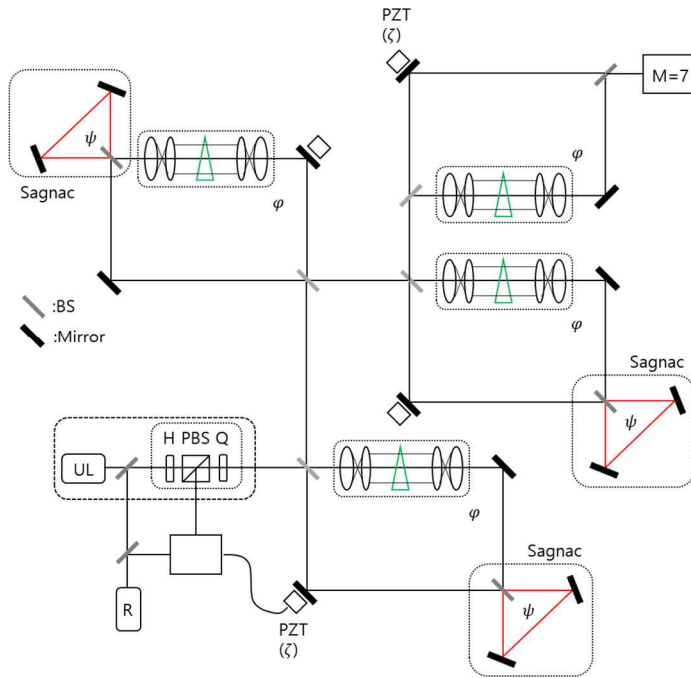

Fig. S5. $M=7$ CBW quantum wavemeter. All MZIs are identical, where the phase control of φ_S is synchronized, respectively.

Figure S6 is for the $M=8$ CBW quantum wavemeter, which is extended from the inset of Fig. 1. For this, all Fizeau-MZIs are identically controlled for the corresponding phases.

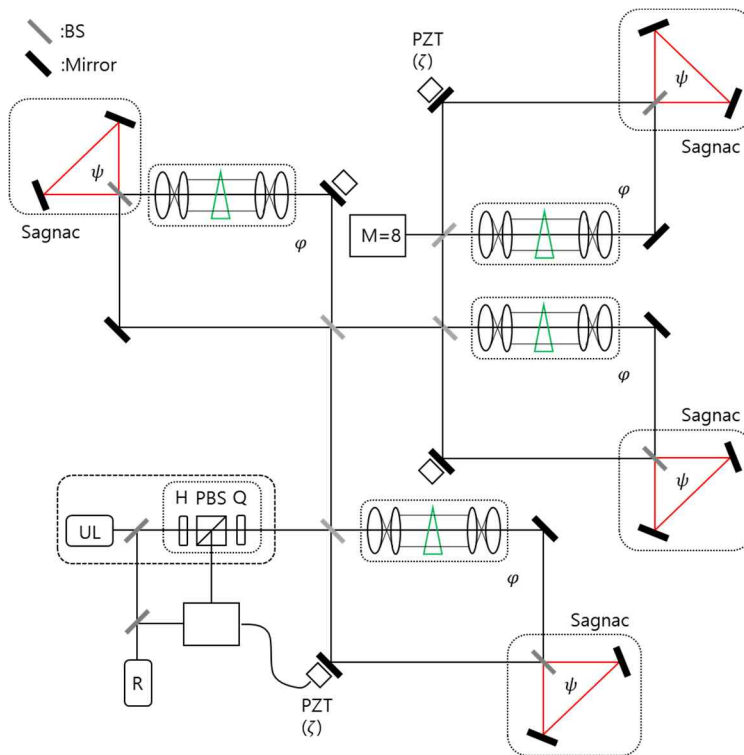

Fig. S6. $M=8$ CBW quantum wavemeter. All Fizeau-MZIs are identical with synchronized phase controls.